



**S1250  
MANURE  
SPREADER  
PARTS BOOK**

Part #93351 HSMFG110321 Rev. #01 Starting Ser. #222GD50002

**STRONG HERITAGE - STRONG PEOPLE - STRONGER FUTURE**





# INSTRUCTIONS FOR ORDERING PARTS

All service parts should be ordered through your authorized H&S dealer. Your Dealership will be able to give you faster service if you will provide them with the following:

1. All references to left or right apply to the machine as viewed from the rear.
2. Parts should not be ordered from illustration only. Please order complete part number.
3. If your dealer has to order parts - give shipping instructions:

VIA truck - large pieces (please specify local truck lines)

VIA United Parcel Service (include full address)

PLEASE RECORD NUMBERS FOR YOUR UNIT FOR QUICK REFERENCE

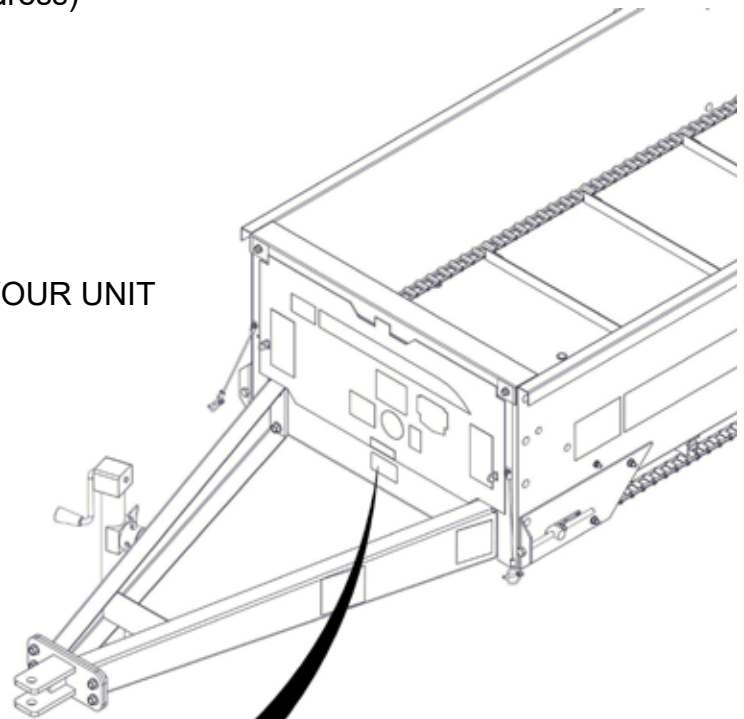

<b>H&amp;S MFG. CO. INC.</b>	
MARSHFIELD, WIS.	
MOD. NO.	<input type="text"/>
SER. NO.	<input type="text"/>
DESCR.	<input type="text"/>

H&S IS CONTINUALLY STRIVING TO IMPROVE ITS PRODUCTS

We must, therefore, reserve the right to make improvements or changes whenever it becomes practical to do so, without incurring any obligation to make changes or additions to the equipment previously sold.





**FIGURE 1**  
**FRONT POLE & COMPONENTS**

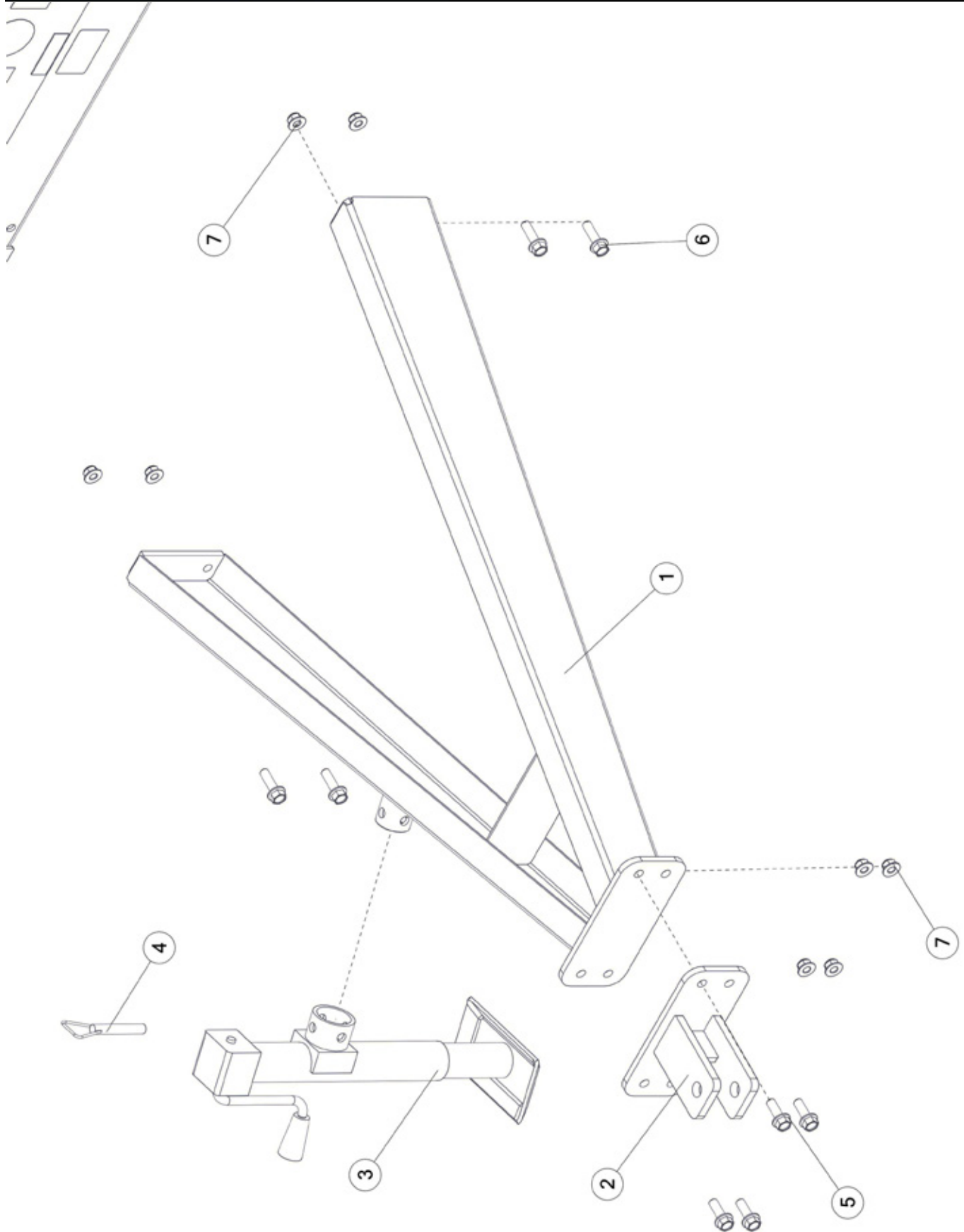



# FIGURE 1

## FRONT POLE & COMPONENTS

REF #	PART #	DESCRIPTION	QTY
1	93291B	POLE W/DECALS	1
2	91186	HITCH	1
3	12N116	SIDE WIND JACK, 2000#	1
4	12N117	JACK PIN	1
5	YBFB16150	BOLT FLANGE, 1/2 X 1-1/2 G5	4
6	YBFB16175	BOLT FLANGE, 1/2 X 1-3/4 G5	4
7	YNFG16003	NUT FLANGE, 1/2 GF	8



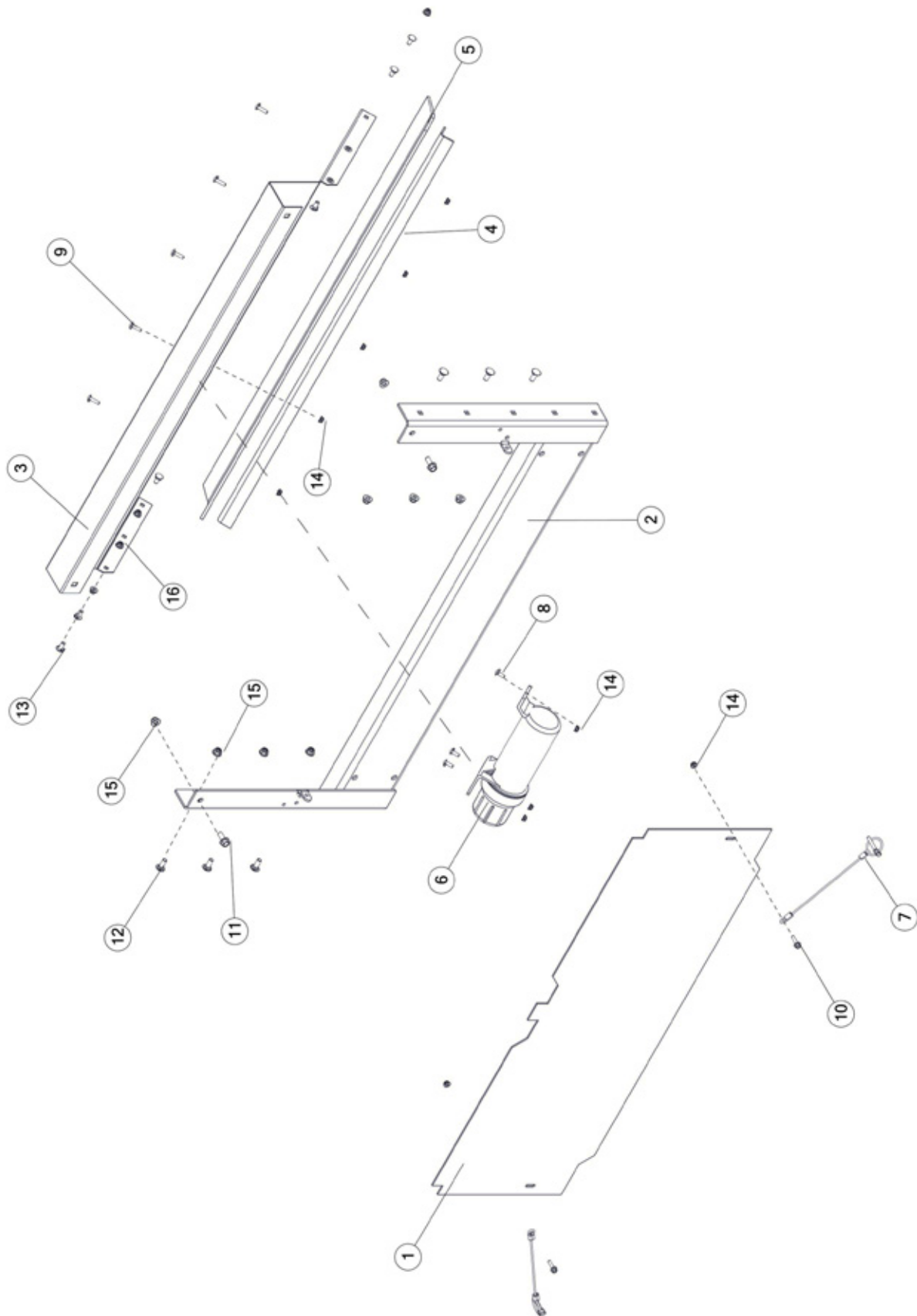



# FIGURE 2

## FRONT SHIELD & COMPONENTS

REF #	PART #	DESCRIPTION	QTY
1	5N54B	SHIELD, FRONT W/ DECALS	1
2	5N10	SUPPORT, FRONT	1
3	93113B	SHIELD, FRONT W/ DECAL	1
4	5N44	STRAP	1
5	5N45	PANEL RUBBER, FRONT	1
6	S522	MANUAL HOLDER	1
7	S122	LYNCH PIN W/CABLE	2
8	YBCR08040	BOLT CARRIAGE, 1/4 X 3/4 G5	3
9	YBCR08005	BOLT CARRIAGE, 1/4 X 1 G5	5
10	YBFB08100	BOLT FLANGE, 1/4 X 1 G5	2
11	YBFB12003	BOLT FLANGE, 3/8 X 1 G5 ZC	2
12	YBCR12010	BOLT CARRIAGE, 3/8 X 1 G5	6
13	YBCR10030	BOLT CARRIAGE, 5/16 X 3/4 G5	6
14	YNFG08010	NUT FLANGE , 1/4 GF	10
15	YNFG12006	NUT FLANGE, 3/8 GF	8
16	YNFG10005	NUT FLANGE, 5/16 GF	6



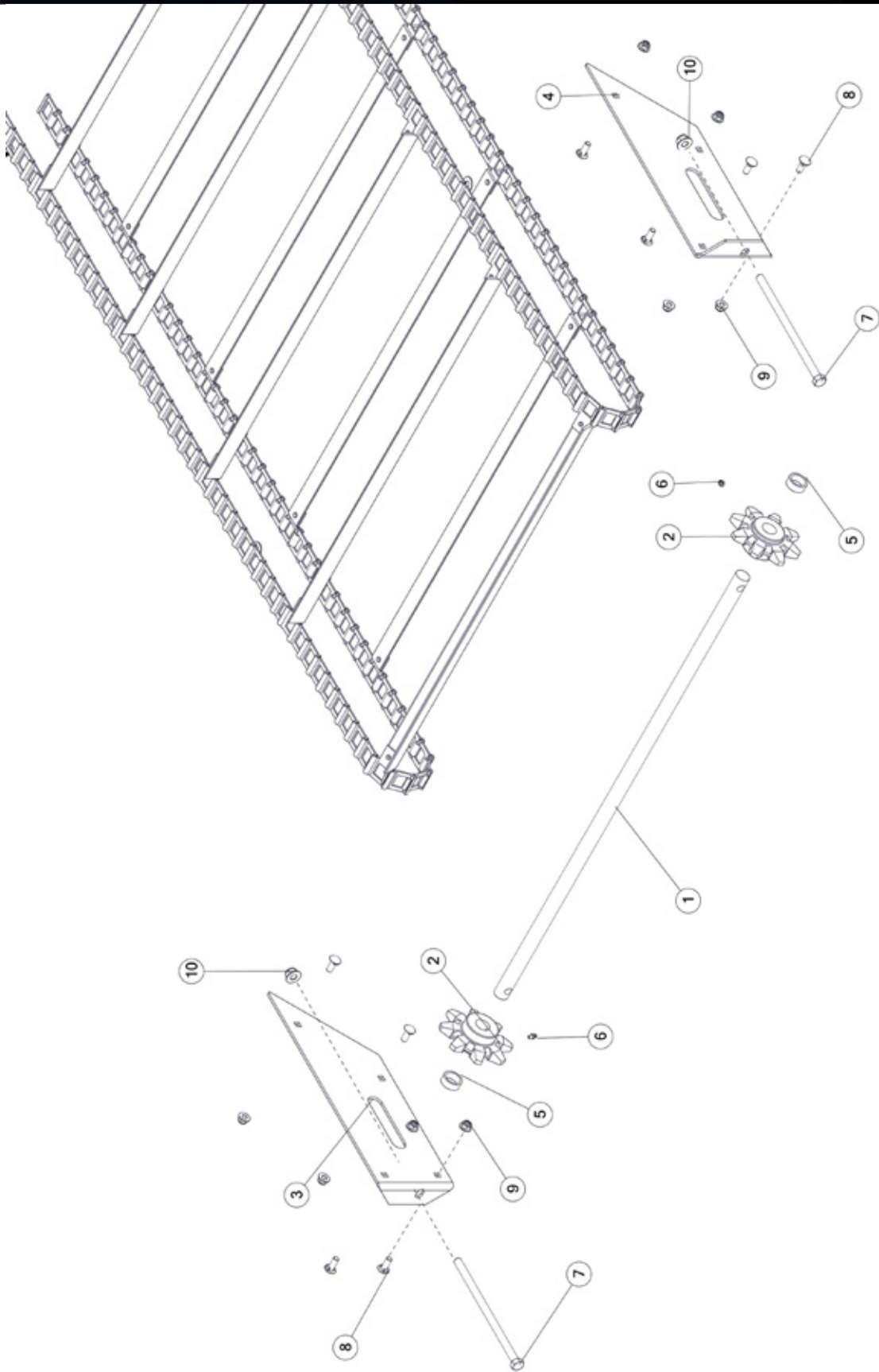
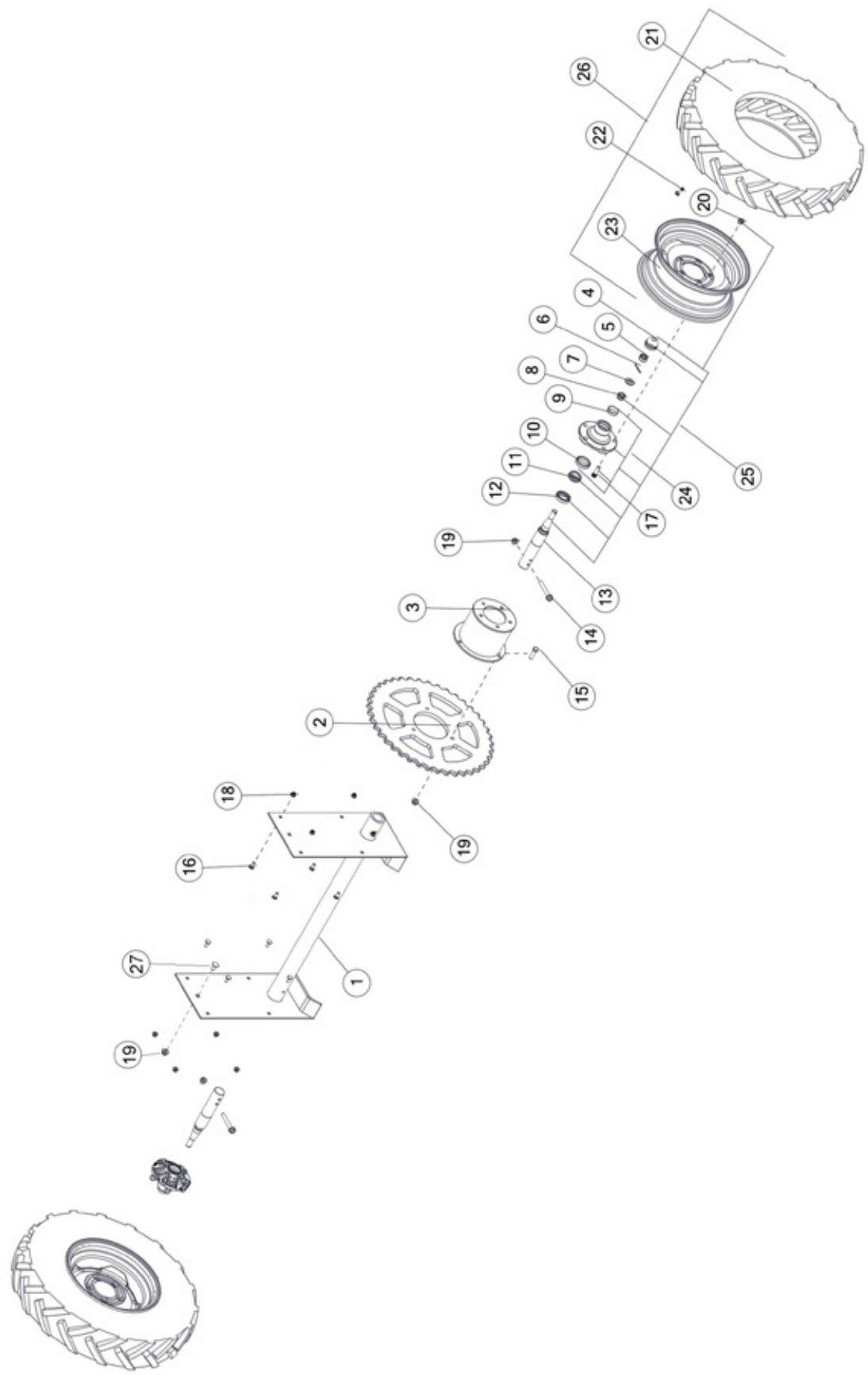







**FIGURE 4**  
**AXLE, HUB, TIRES & COMPONENTS**





# FIGURE 4

## AXLE, HUB, TIRES & COMPONENTS

REF #	PART #	DESCRIPTION	QTY
1	5N15	AXLE	1
2	87523	SPROCKET	1
3	87708	HUB DRUM	1
4	BFR66	HUB CAP	2
5	YNSL24010	NUT HEX, SLOTTED, 3/4 G2	2
6	YPCT05010	COTTER PIN 5/32 X 1-1/2	2
7	YWFL24010	WASHER FLAT, 3/4	2
8	BFR62	OUTER BEARING	2
9	BFR61	OUTER RACE	2
10	17G146	OUTER RACE	2
11	17G145	TAPERED ROLLER BEARING, 2.16 X 1.25 X .66	2
12	60699	SEAL	2
13	5N61	SPINDLE	2
14	YBFB16350	BOLT FLANGE, 1/2 X 3-1/2 G5	2
15	YBHH16055	BOLT HEX, 1/2 X 1-3/4 G5	6
16	YBCR12010	BOLT CARRIAGE, 3/8 X 1 G5	8
17	YBSD16005	BOLT STUD, 1/2 X 1-7/8 X 3/8 G5	10
18	YNFG12006	NUT FLANGE, 3/8 GF	8
19	YNFG16003	NUT FLANGE, 1/2 GF	6
20	YNWL16005	NUT WHEEL, 1/2 G5	10
21	5N46	TIRE, TRACTOR LUG	2
22	72436	VALVE STEM, 1-1/2 RUBBER	2
23	5N63SR	WHEEL 15 X 6, SILVER	2
24	BFR60	HUB WITH RACES & STUDS	2
25	86812	HUB SUB ASSEMBLY	2
26	69981SR	TIRE & WHEEL ASSEMBLY, SILVER, LH	1
*	69982SR	TIRE & WHEEL ASSEMBLY, SILVER, RH	1
27	YBCR16005	BOLT CARRIAGE, 1/2 X 1 G5	1





# FIGURE 5 REAR SUPPORT & COMPONENTS

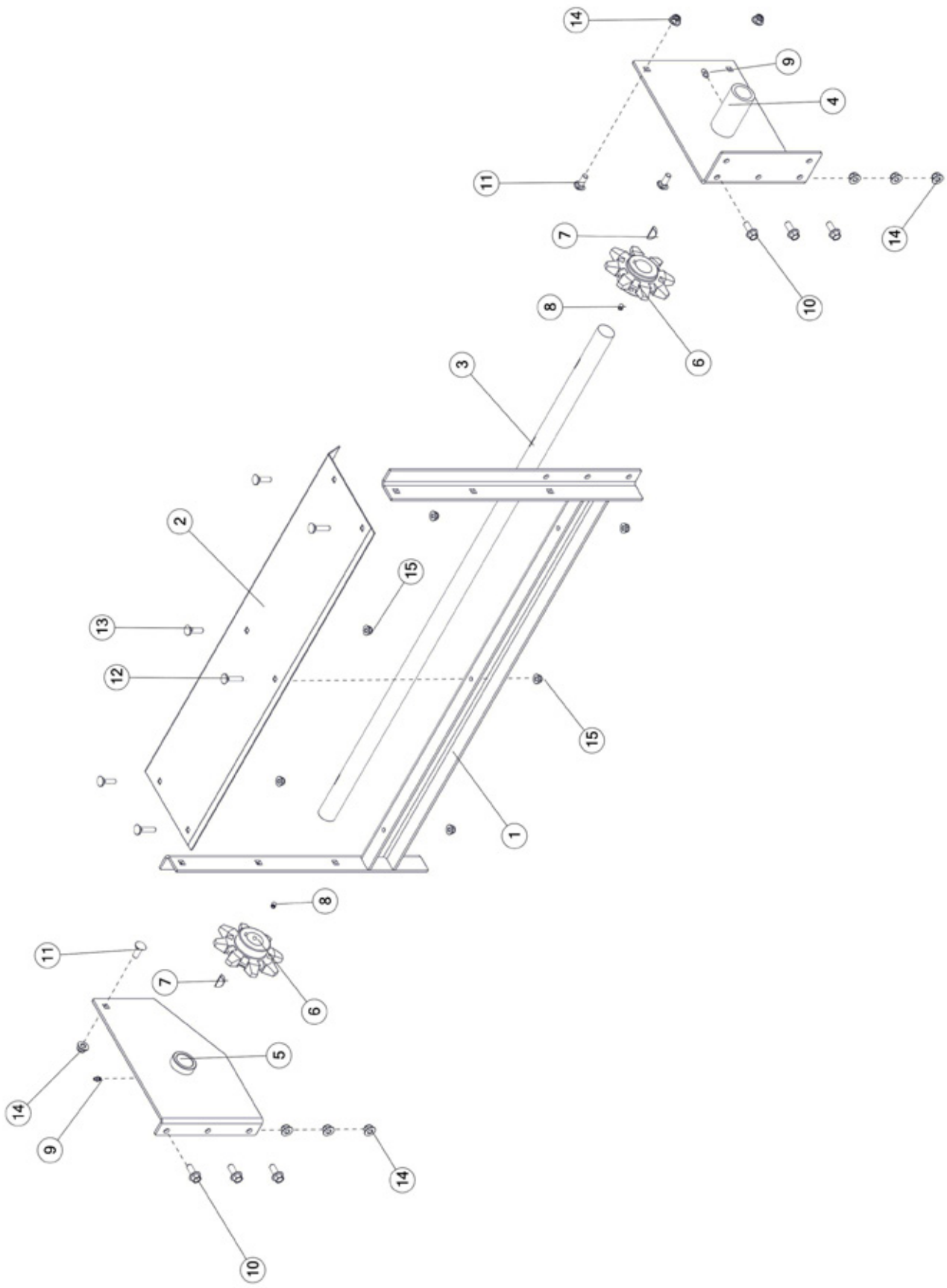



# FIGURE 5

## REAR SUPPORT & COMPONENTS

REF #	PART #	DESCRIPTION	QTY
1	5N3	SUPPORT, REAR	1
2	5N69	DRIVE SHAFT COVER	1
3	5N25	APRON DRIVE SHAFT	1
4	5N12	DRIVE SHAFT BRACKET LH	1
5	5N11	DRIVE SHAFT BRACKET RH	1
6	5N42	APRON DRIVE SPROCKET	2
7	G12	WOODRUFF KEY, 5/16 X 1	2
8	YSKP10010	SCREW SOCKET HEAD, 5/16 X 3/8	2
9	G89	STRAIGHT ZERK, 1/4-28 X 90	2
10	YBFB12003	BOLT FLANGE, 3/8 X 1 G5 ZC	6
11	YBCR12010	BOLT CARRIAGE, 3/8 X 1 G5	2
12	YBCR10015	BOLT CARRIAGE, 5/16 X 1-1/2 G5	3
13	YBCR10020	BOLT CARRIAGE, 5/16-18 X 1-1/4 G5 ZC	3
14	YNFG12006	NUT FLANGE, 3/8 GF	9
15	YNFG10005	NUT FLANGE, 5/16 GF	6





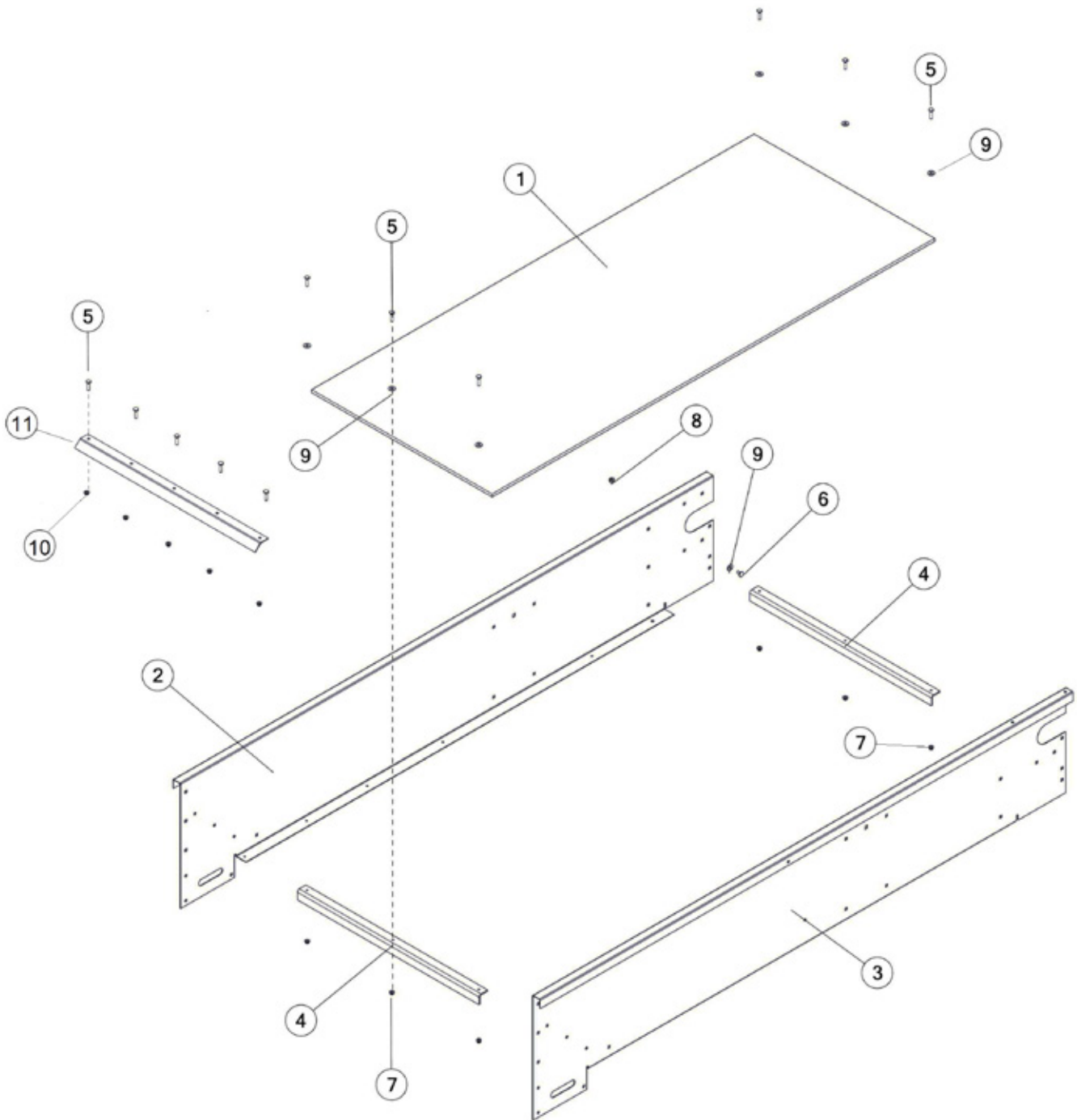

# FIGURE 6

## FLOOR & SIDE COMPONENTS



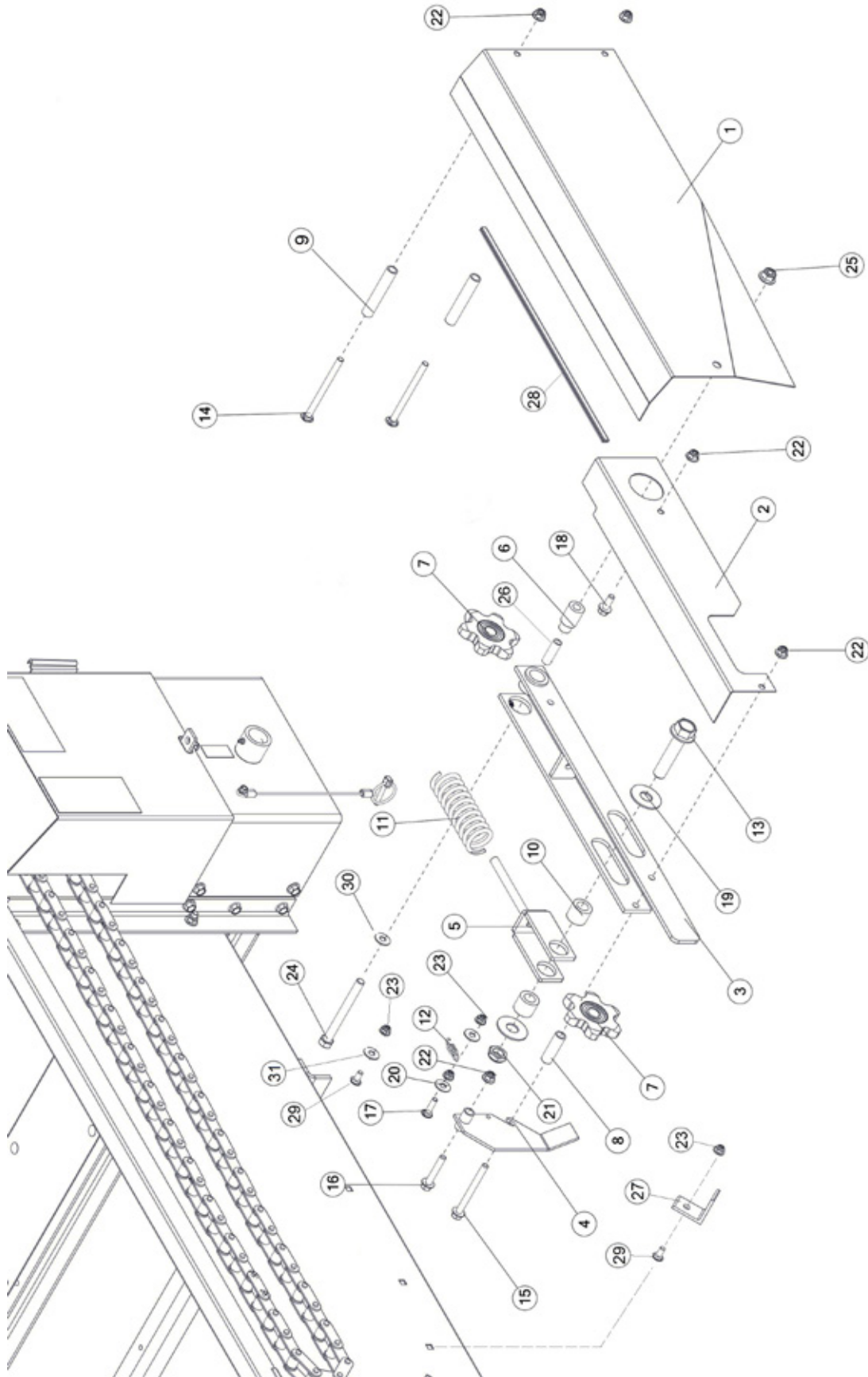







# FIGURE 7

## PIVOT ARM, SPRINGS & COMPONENTS

REF #	PART #	DESCRIPTION	QTY
1	92031B	SHIELD, STATIONARY W/DECALS	1
2	92032B	SHIELD, ROTARY W/DECALS	1
3	5N28	PIVOT ARM	1
4	5N35	LATCH	1
5	5N27	IDLER SPRING BRACKET	1
6	86074	PIVOT OUTSIDE SPACER	1
7	86075	IDLER SPROCKET	2
8	5N34	PIVOT ARM SPACER	1
9	5N36	SHIELD SPACER	2
10	86072	SLIDING IDLER SPACER	2
11	S109	SPRING	1
12	12R3	RATCHET DOG SPRING	1
13	YBFB24350	BOLT FLANGE, 3/4 X 3-1/2 G5	2
14	YBCR12115	BOLT CARRIAGE, FT, 3/8-16 X 5 G5 ZC	2
15	YBFB12400	BOLT FLANGE, 3/8 X 4 G5	1
16	YBFB12225	BOLT FLANGE, 3/8 X 2-1/4 G5	1
17	YBCR10020	BOLT CARRIAGE, 5/16-18 X 1-1/4 G5 ZC	1
18	YBFB12003	BOLT FLANGE, 3/8 X 1 G5 ZC	1
19	YWFL24005	WASHER FLAT, 3/4	2
20	YWFL12005	WASHER FLAT , 3/8 G5	2
21	YNNJ24005	NUT JAM, 3/4 G2	1
22	YNFG12006	NUT FLANGE, 3/8 GF	5
23	YNFG10005	NUT FLANGE, 5/16 GF	4
24	YBHH16156	BOLT HEX, FT, 1/2-13 X 5 G5 ZC	1
25	YNFG16003	NUT FLANGE, 1/2 GF	1
26	86073	INSIDE BUSHING	1
27	ST33	TIGHTENER	1
28	5N73	EDGE GUARD, 1/8 X 18	1
29	YBCR10030	BOLT CARRIAGE, 5/16 X 3/4 G5	2
30	YWFL16005	WASHER FLAT, 1/2	1
31	YWFL14005	WASHER FLAT, 7/16	1





# FIGURE 8 RACHET GEAR COMPONENTS

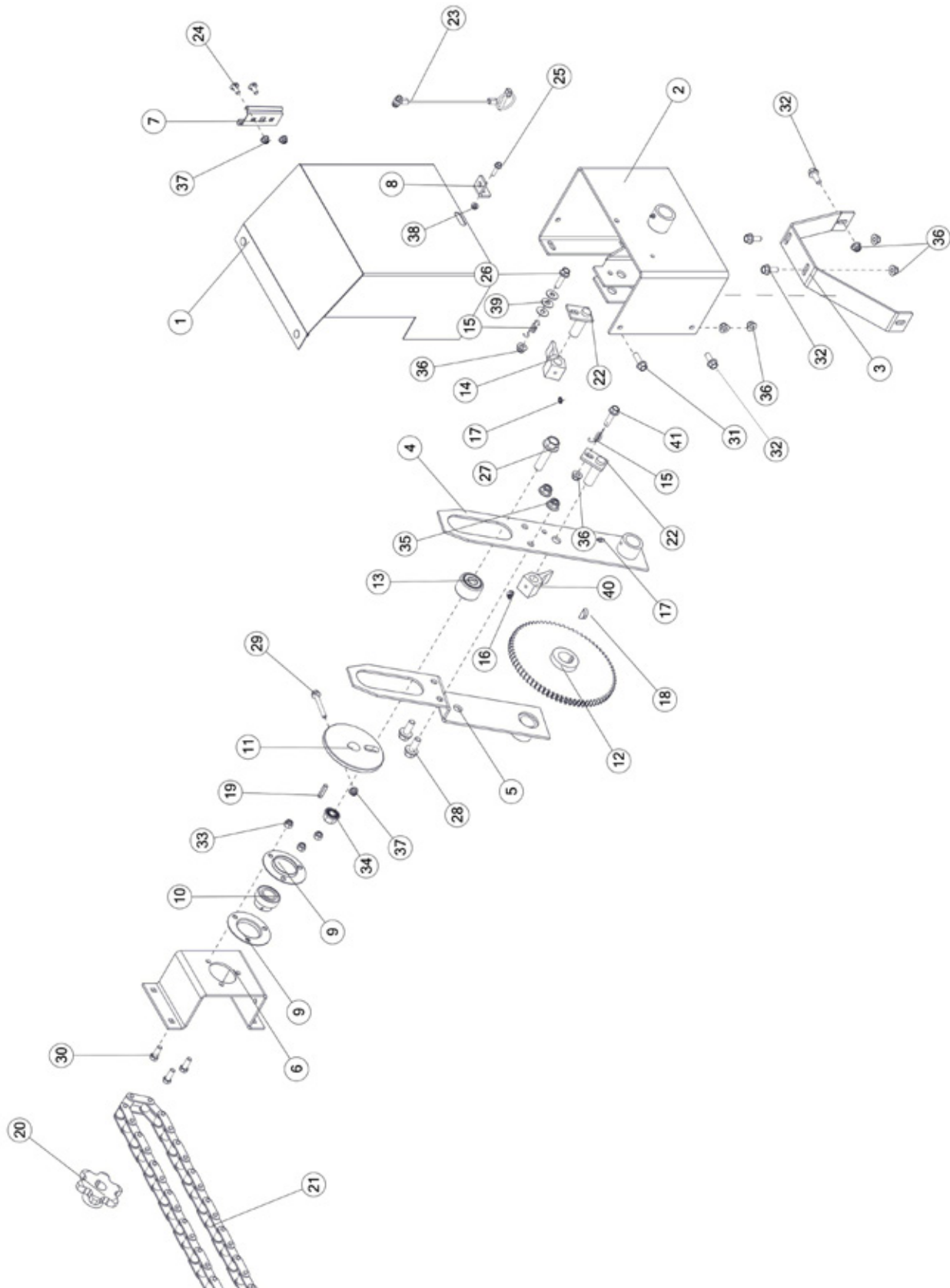



# FIGURE 8

## RACHET GEAR COMPONENTS

REF #	PART #	DESCRIPTION	QTY
1	5N32B	SHIELD W/DECALS, REAR	1
2	5N17	APRON MECHANISM COVER, LH	1
3	5N50	BEATER MOUNT RE-ENFORCEMENT	1
4	5N13	RECIPROCATOR FACE	1
5	5N14	RECIPROCATING ARM	1
6	5N16	BEATER BRACKET	1
7	F97	SMV BRACKET	1
8	5N53	BACK SHIELD ANGLE	1
9	4C7	FLANGE BEARING	2
10	4C8	BEARING W/COLLAR, 1	1
11	5N23	BEATER CAM HUB	1
12	5N21	RATCHET GEAR	1
13	T66	CAM BEARING	1
14	5N20	HOLDING DOG W/STRAIGHT ZERK	1
15	23N186	TORSION SPRING	2
16	RG21	GREASE ZERK, 45 DEGREE	1
17	G89	STRAIGHT ZERK, 1/4-28 X 90	2
18	G12	WOODRUFF KEY, 5/16 X 1	1
19	S135	SQUARE KEY, 1/4 X 1-1/4	1
20	5N76	BEATER SPROCKET, 6	1
21	5N57	DRIVE CHAIN	1
*	K121	CONNECTING LINK	1
22	5N26	DOG PIN	2
23	S122	LYNCH PIN W/CABLE	1
24	YBCR10030	BOLT CARRIAGE, 5/16 X 3/4 G5	2
25	YBFB08100	BOLT FLANGE, 1/4 X 1 G5	1
26	YBFB12150	BOLT FLANGE, 3/8 X 1-1/2 G5	1
27	YBFB20250	BOLT FLANGE, 5/8 X 2-1/2 G5	1
28	YBFB16125	BOLT FLANGE, 1/2 X 1-1/4 G5	2
29	YBFB10250	BOLT FLANGE, 5/16 X 2-1/2 G5	1
30	YBHH12010	BOLT HEX, 3/8 X 1 G5	3





# FIGURE 8 RACHET GEAR COMPONENTS

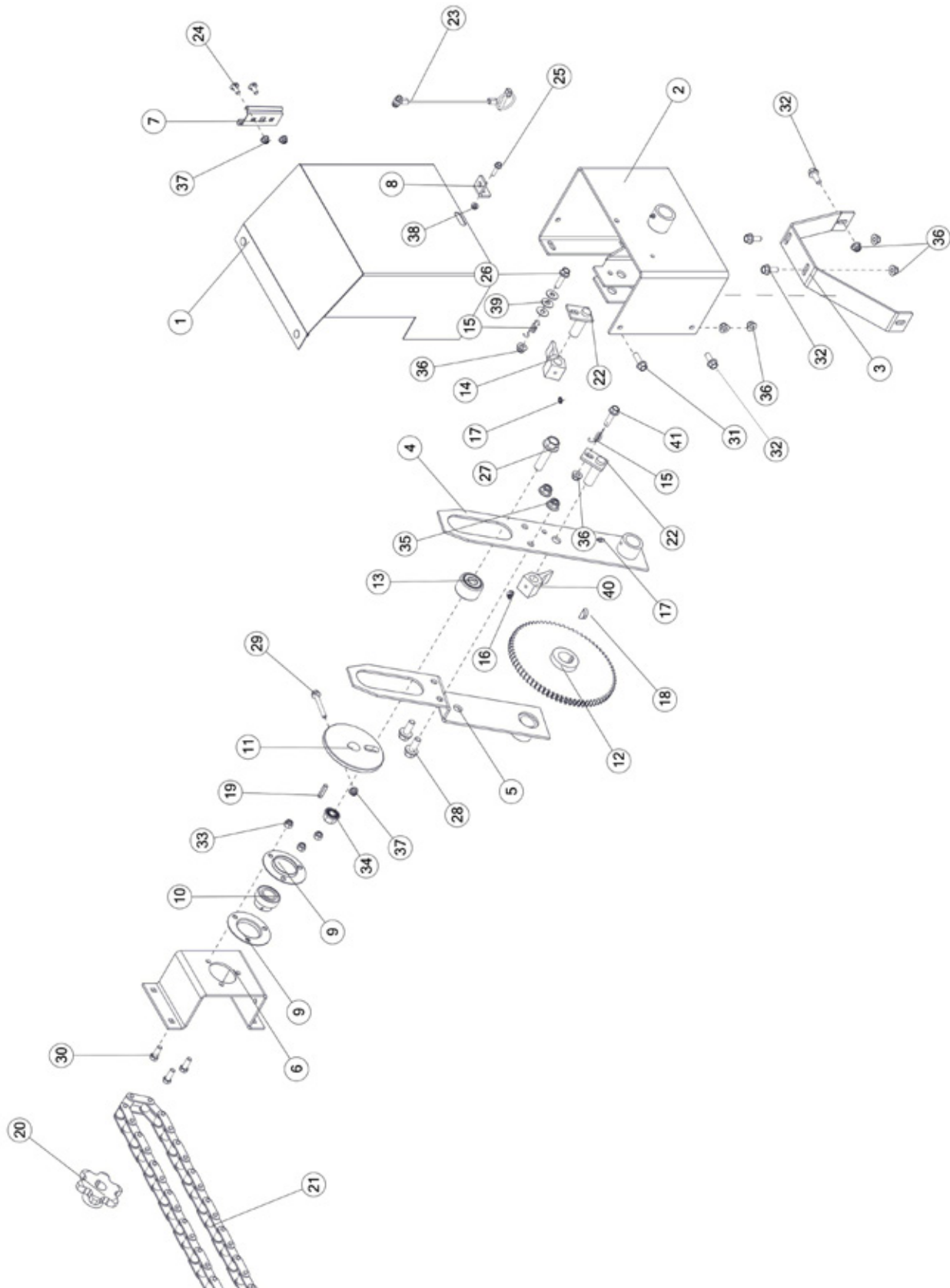





# FIGURE 9 BEATER & COMPONENTS

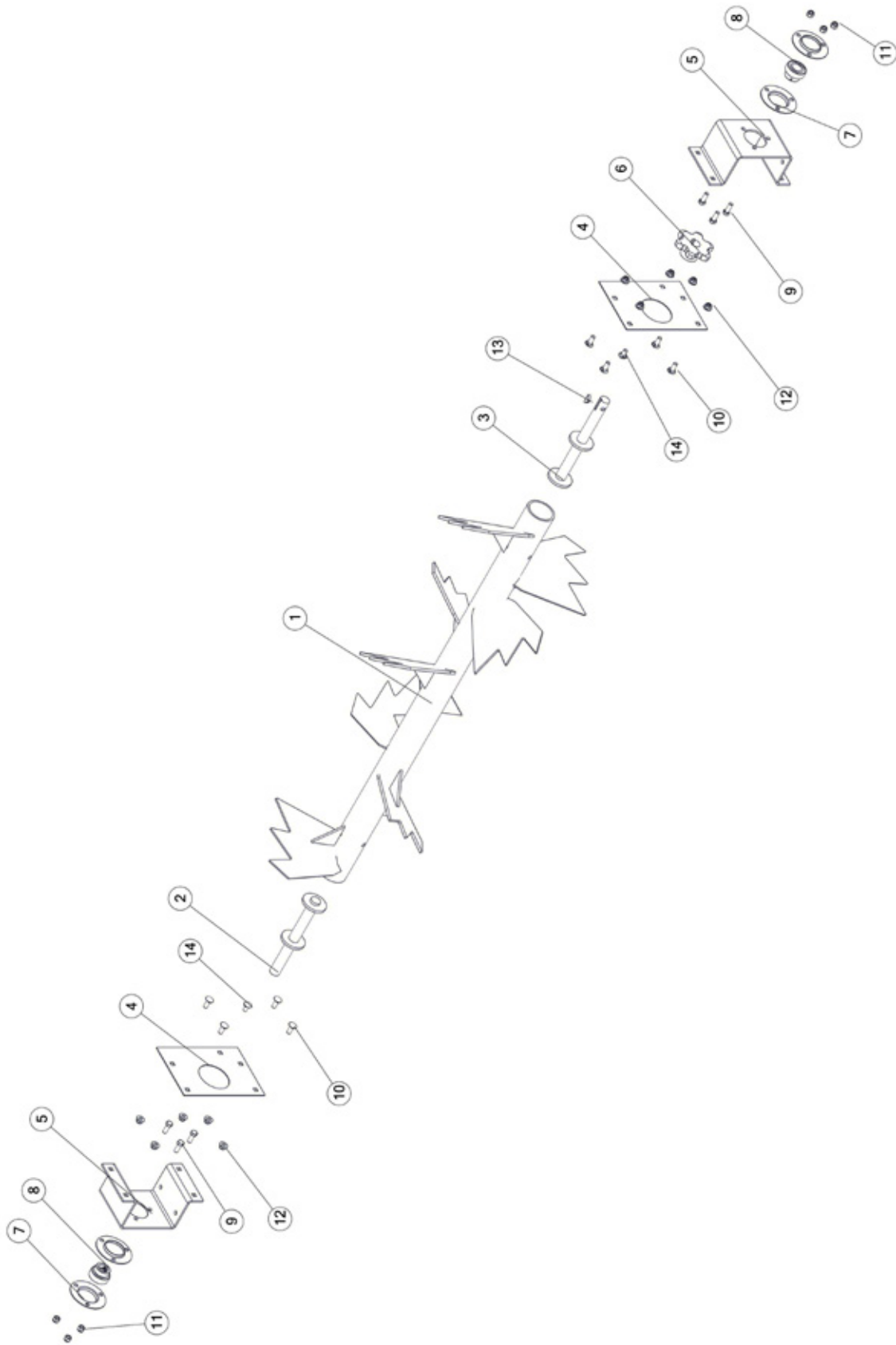





# FIGURE 10

## APRON CHAIN & COMPONENTS

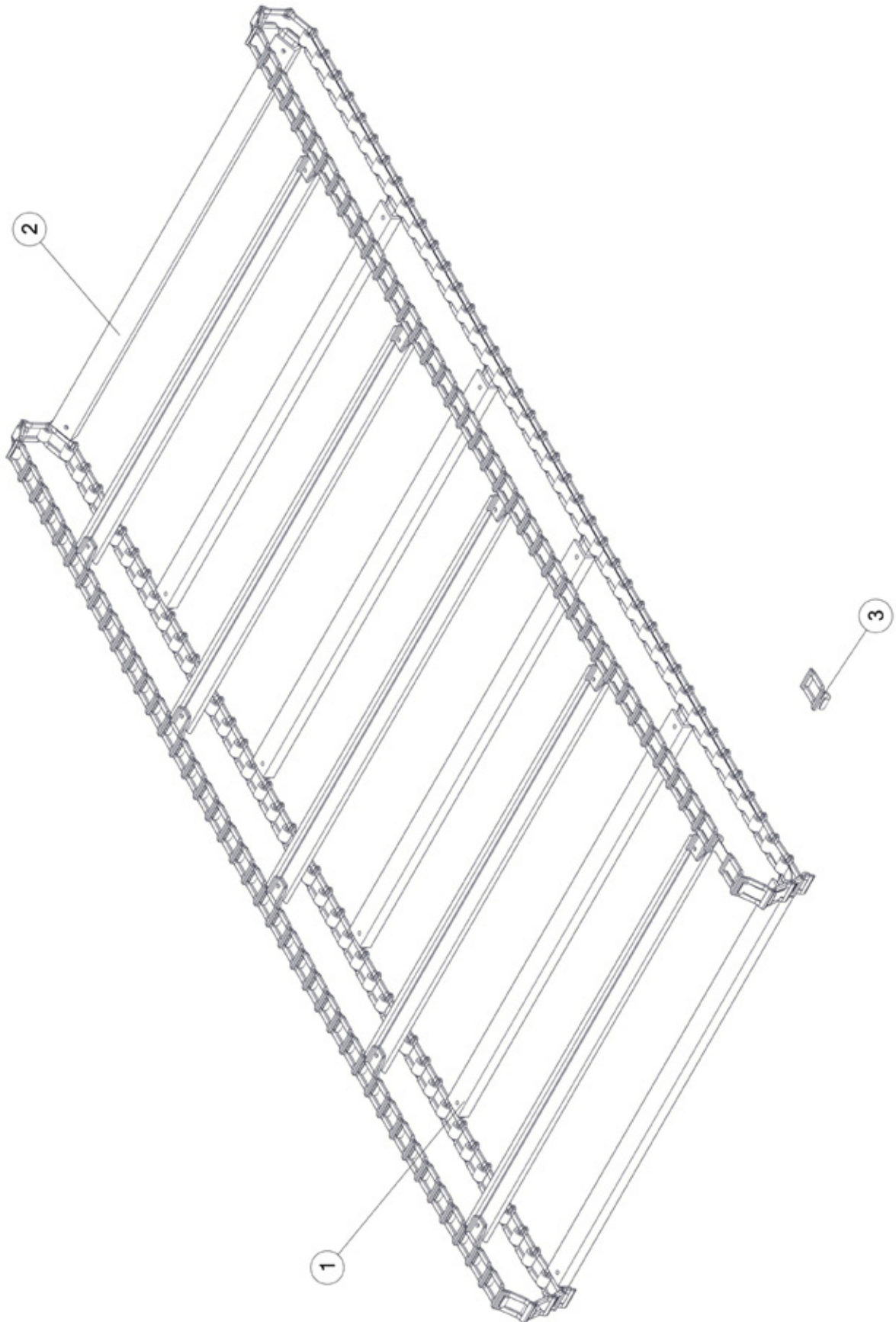





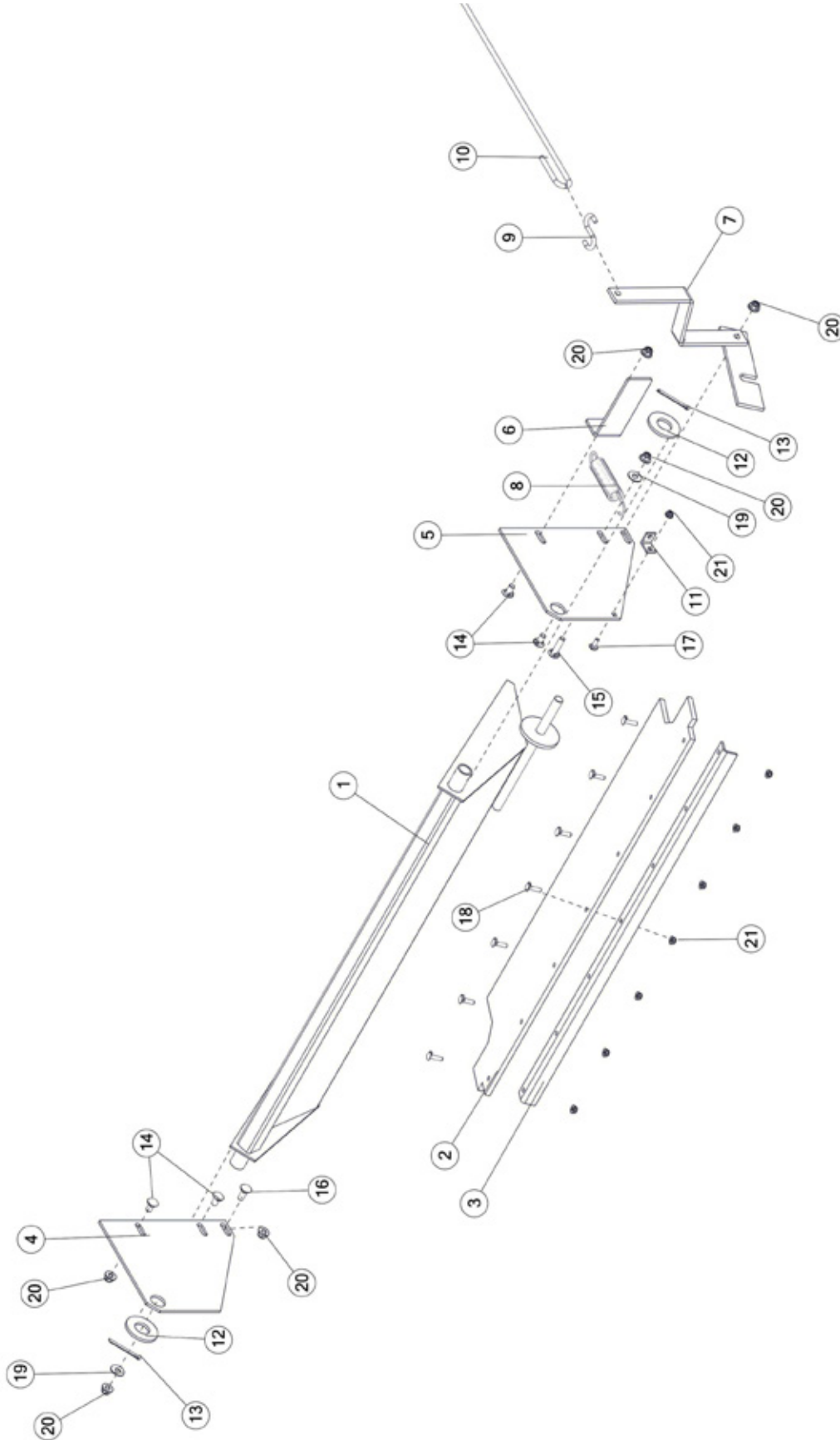



# FIGURE 11 OPTIONAL REAR PAN (MSO3D)

REF #	PART #	DESCRIPTION	QTY
1	5N66	PAN	1
2	5N65	PAN RUBBER	1
3	5N64	PAN ANGLE	1
4	80N2	PAN LH	1
5	80N3	PAN RH	1
6	80N82	PAN HANDLE STOP	1
7	5N67	PAN HANDLE	1
8	R27	PAN HANDLE SPRING	1
9	YMHK92005	S-HOOK, .262 X 2-1/4 X 11/16	1
10	80N6	TRIP ROPE	1
11	R26	SPRING BRACKET	1
12	R3	PAN SPACER	2
13	YPCT06020	COTTER PIN, 3/16 X 2	2
14	YBCR12065	BOLT CARRIAGE, 3/8 X 3/4 G5	4
15	YBCR12015	BOLT CARRIAGE, 3/8-16 X 1-1/2 G5	1
16	YBCR12010	BOLT CARRIAGE, 3/8 X 1 G5	1
17	YBCR08040	BOLT CARRIAGE, 1/4 X 3/4 G5	1
18	YBCR08005	BOLT CARRIAGE, 1/4 X 1 G5	7
19	YWFL12005	WASHER FLAT, 3/8 G5	2
20	YNFG12006	NUT FLANGE, 3/8 GF	6
21	YNFG08010	NUT FLANGE, 1/4 GF	8







# **H&S MFG. CO.**

products approved

for the

**FEMA**

**SEAL OF QUALITY**



Manufactured by:

**H&S MANUFACTURING CO., INC.**

2608 S. HUME AVE. MARSHFIELD, WI 54449

(715) 387-3414 | [hsmfgco.com](http://hsmfgco.com)

